

CS 3041
CS 3082

OWNER MANUAL
MANUALE D'USO

SOUND COLUMNS

DIFFUSORI SONORI
A COLONNA



**IMPORTANT NOTES**

Before connecting and using this product, please read this instruction manual carefully and keep it on hand for future reference. This manual is to be considered an integral part of this product and must accompany it when it changes ownership as a reference for correct installation and use as well as for the safety precautions.

RCF S.p.A. will not assume any responsibility for the incorrect installation and / or use of this product.

SAFETY AND OPERATING PRECAUTIONS

1. All the precautions, in particular the safety ones, must be read with special attention, as they provide important information.

2. Loudspeaker lines (amplifier outputs) can have a sufficiently high voltage (i.e. 100-70 V) to involve a risk of electrocution: never install or connect this loudspeaker when amplifiers are switched on.

3. Make sure all connections have been made correctly and the loudspeaker input voltage is suitable for the amplifier output.

4. Protect loudspeaker lines from damage. Make sure they are positioned in a way that they cannot be stepped on or crushed by objects.

5. Make sure that no objects or liquids can get into this product, as this may cause a short circuit.

6. Never attempt to carry out any operations, modifications or repairs that are not expressly described in this manual.

Contact your authorized service centre or qualified personnel should any of the following occur:

- The loudspeaker does not function (or works in an anomalous way).
- The cable has been damaged.
- Objects or liquids have got into the unit.
- The loudspeaker has been damaged due to heavy impacts or fire.

7. Should the loudspeaker emit any strange odours or smoke, remove it from the line after having immediately switched the amplifier off.

8. Do not connect this product to any equipment or accessories not foreseen. For suspended installation, only use the dedicated anchoring points and do not try to hang this loudspeaker by using elements that are unsuitable or not specific for this purpose.

Also check the suitability of the support surface to which the product is anchored (wall, ceiling, structure, etc.), and the components used for attachment (screw anchors, screws, brackets not supplied by RCF etc.), which must guarantee the security of the system / installation over time, also considering, for example, the mechanical vibrations normally generated by transducers.

IMPORTANT NOTES

9. RCF S.p.A. strongly recommends this product is only installed by professional qualified installers (or specialised firms) who can ensure a correct installation and certify it according to the regulations in force.

The entire audio system must comply with the current standards and regulations regarding electrical systems.

10. There are numerous mechanical and electrical factors to be considered when installing a professional audio system (in addition to those which are strictly acoustic, such as sound pressure, angles of coverage, frequency response, etc.).

11. Hearing loss

Exposure to high sound levels can cause permanent hearing loss. The acoustic pressure level that leads to hearing loss is different from person to person and depends on the duration of exposure.

To prevent potentially dangerous exposure to high levels of acoustic pressure, anyone who is exposed to these levels should use adequate protection devices.

When a transducer capable of producing high sound levels is being used, it is necessary to wear ear plugs or protective earphones.

See the technical specifications in the instruction manual for the maximum sound pressure the loudspeaker is capable of producing.

12. To ensure a correct sound reproduction, loudspeaker phase is to be respected (loudspeakers are connected respecting the amplifier polarity). This is important when loudspeakers are installed adjacent one another, for instance, in the same room.

13. To prevent inductive effects from causing hum, noise and a bad system working, loudspeaker lines should not be laid together with other electric cables (mains), microphone or line level signal cables connected to amplifier inputs.

14. The loudspeaker cable shall have wires with a suitable section (twisted, if possible, to reduce inductive effects due to surrounding electro-magnetic fields) and a sufficient electrical insulation. Refer to local regulations since there may be additional requirements about cable characteristics.

15. Install this loudspeaker far from any heat source.

16. Do not use solvents, alcohol, benzene or other volatile substances for cleaning the external parts of this product.

RCF S.P.A. THANKS YOU FOR PURCHASING THIS PRODUCT, WHICH HAS BEEN DESIGNED TO GUARANTEE RELIABILITY AND HIGH PERFORMANCE.

DESCRIPTION



CS 3041 and CS 3082 are sound columns that are ideal for speech reproduction, with a shape designed to allow corner installation. The extruded aluminium body and its metal grille are painted in white RAL 9016.

The wall mounting accessories are included.

CS 3041

Four extended range 2" loudspeakers and one 1" tweeter.
Built-in multi-tapped transformer (10 – 15 – 20 W) for 100 V constant voltage connection.
A 16 ohm input is available on the terminal strip.

CS 3041

CS 3082

Eight extended range 2" loudspeakers and two 1" tweeters.
Built-in multi-tapped transformer (10 – 20 – 30 W) for 100 V constant voltage connection.
A 8 ohm input is available on the terminal strip.

CS 3082

CONNECTIONS



WARNING: loudspeaker connections should be only made by qualified and experienced personnel having the technical know-how or sufficient specific instructions to ensure that connections are made correctly and to prevent any electrical danger.

To prevent any risk of electric shock, do not connect loudspeakers when the amplifier is switched on.

Before turning the system on, check all connections and make sure there are no accidental short circuits.

The entire sound system shall be designed and installed in compliance with the current local laws and regulations regarding electrical systems.

On the loudspeaker bottom, there are the screw terminals for the 100 V constant voltage line connection coming from an amplifier. It is possible to choose among 3 different power values (CS 3041: 10 – 15 – 20 W, CS 3082: 10 – 20 – 30 W).

NOTE: A 70 V CONNECTION (INSTEAD OF 100 V) ENTAILS THAT THE SELECTED POWER IS HALVED.

WARNING



The fifth screw terminal (red wire) allows the loudspeaker connection to an amplifier low impedance output (usually 4 – 8 Ω).
 Remove the loudspeaker bottom cover (by unscrewing the 2 screws) to access its terminal strip. The cable shall pass through the loudspeaker rear hole.

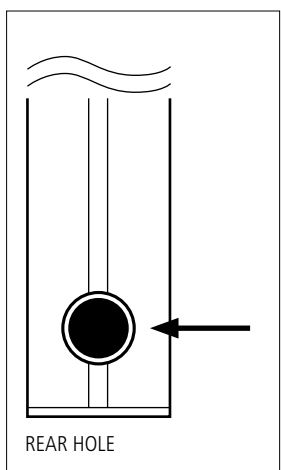
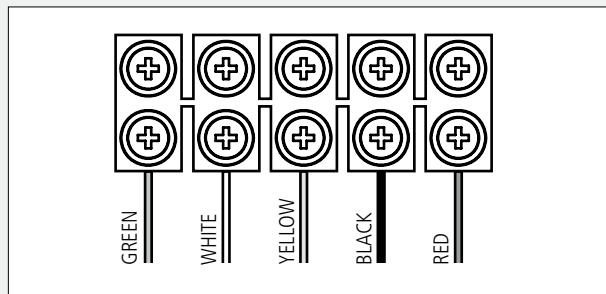

CS 3041	COLOUR	VOLTAGE	POWER	IMPEDANCE
	green	100 V	10 W	1000 Ω
	white	100 V	15 W	667 Ω
	yellow	100 V	20 W	500 Ω
	black	common		
	red		20 W	16 Ω

CS 3082	COLOUR	VOLTAGE	POWER	IMPEDANCE
	green	100 V	10 W	1000 Ω
	white	100 V	20 W	500 Ω
	yellow	100 V	30 W	333 Ω
	black	common		
	red		30 W	8 Ω

100 V CONSTANT VOLTAGE LINE:

Connect the amplifier output marked with '0', 'b' or 'COM' to the loudspeaker common input (black wire).
 Connect the amplifier 100 V output (terminal marked with '100 V' or 'a') to one (only) of the 3 loudspeaker 100 V inputs (according to the chosen power).
 NOTE: Do NOT CONNECT THE 100 V LINE TO THE LOUDSPEAKER LOW IMPEDANCE INPUT (RED WIRE).

AMPLIFIER WITH LOW IMPEDANCE (4 – 8 Ω) LOUDSPEAKER OUTPUTS:

Connect the amplifier '-' output to the loudspeaker common input (black wire).
 Connect the amplifier '+' output to the loudspeaker low impedance input (red wire).

100 V CONSTANT VOLTAGE LINE



AMPLIFIER WITH LOW IMPEDANCE (4 – 8 Ω) LOUDSPEAKER OUTPUTS



- The loudspeaker input voltage (V_d) shall correspond to the amplifier output voltage (V_a).
- The sum of nominal power values ($P_d \times n$) of all loudspeakers connected to the line shall not exceed the amplifier power (P_a).
- Make sure all loudspeakers are connected in phase to ensure a correct sound reproduction.

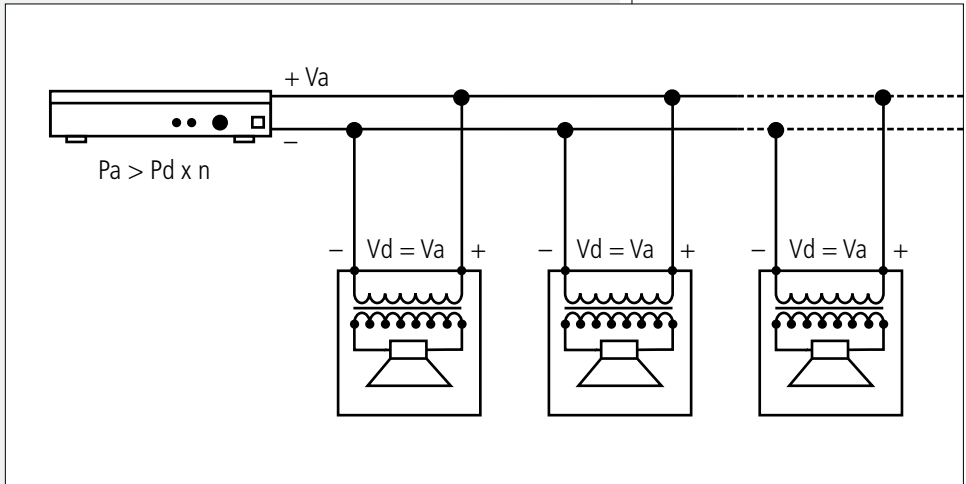

- Always use cables having wires with an adequate cross-section, considering the cable length and the total loudspeaker power.
- Loudspeaker lines must be kept separated from mains cable, microphone cables or others, in order to avoid inductive phenomena may cause hum or noises.
- Use loudspeaker cables having twisted wires to reduce hum caused by inductive effects due to coupling with electromagnetic fields.

NOTES ABOUT LOW IMPEDANCE CONNECTIONS



- The total loudspeaker impedance must not be lower than the amplifier output impedance. Note: a loudspeaker total impedance equal to the amplifier output one permits to get the maximum deliverable power (but an higher loudspeaker impedance entails less power).
- The total impedance of a group of identical loudspeakers linked in parallel is given by their unit value divided by the loudspeaker quantity.
- The total loudspeaker power shall be adequate for the maximum deliverable power of the amplifier.
- The loudspeaker line shall be as short as possible.

INSTALLATION



WARNING: the loudspeaker is to be installed by qualified personnel, respecting all safety standards.
The loudspeaker must be installed securely, making sure the support structure (walls / ceilings) has the necessary mechanical characteristics for the loudspeaker weight, without the risk of a fall that could damage things or cause an injury.
Use attachment elements suitable for walls / ceilings (e.g. screw anchors for bricks, screw anchors for concrete, etc.).

Fix the 2 brackets to the wall (suggested loudspeaker bottom height: 1.5 ÷ 2.5 metres / 5 ÷ 8 feet).
Connect the loudspeaker (as described in the 'Connections' manual section).
Fix the loudspeaker to the 2 brackets by tightening the 2 bolts.

WARNING

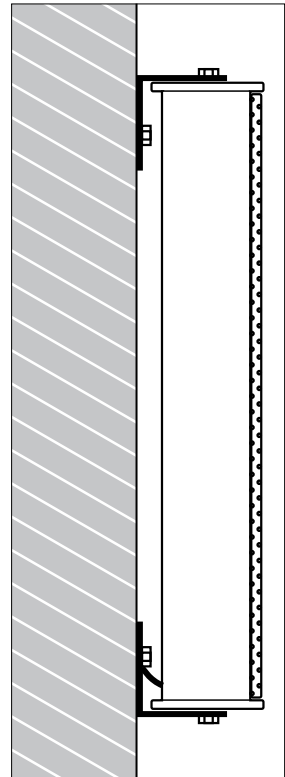

CS 3041 SPECIFICATIONS



Input voltage	100 V (with transformer)
Power	20 – 15 – 10 W / 20 W on 16 Ω
Frequency response	200 Hz ÷ 18 kHz
Sensitivity	89 dB (1 m / 1 W)
Sound pressure (20 W)	102 dB (1 m)
Loudspeakers	4 extended range 2" woofers, 1" tweeter (½" coil)
Cabinet material	Extruded aluminium
Grille	Painted galvanized steel
Colour	Traffic white RAL 9016
Dimensions (w, h, d)	78 mm, 430 mm, 66 mm
Net weight	1.8 kg

CS 3082 SPECIFICATIONS



Input voltage	100 V (with transformer)
Power	30 – 20 – 10 W / 30 W su 8 Ω
Frequency response	200 Hz ÷ 20 kHz
Sensitivity	91 dB (1 m / 1 W)
Sound pressure (30 W)	106 dB (1 m)
Loudspeakers	8 extended range 2" woofers, 2 1" tweeters (½" coil)
Body material	Extruded aluminium
Grille	Painted galvanized steel
Colour	Traffic white RAL 9016
Dimensions (w, h, d)	78 mm, 670 mm, 66 mm
Net weight	2.8 kg



www.rcfaudio.com

RCF SpA: Via Raffaello, 13 - 42124 Reggio Emilia > Italy
tel. +39 0522 274411 - fax +39 0522 274484 - e-mail: rcfservice@rcf.it